

Diesel Generator set 4B3.9 series engine

70kVA - 100kVA 50Hz
60kW - 90kW 60Hz



> Specification sheet

Our energy working for you.™



**Power
Generation**

Description



This generator set is designed in facilities certified to ISO9001 and manufactured in facilities certified to ISO9001 or ISO9002.

This Cummins® Power Generation commercial generator set is a fully integrated power generation system, providing optimum performance, reliability, and versatility for stationary standby, prime power, and continuous duty applications.

Generator Set Performance

Voltage Regulation

Maintains voltage output to within $\pm 1.0\%$.
At any power factor between 0.8 and 1.0
At any variations from No load to Full load.
At any variations from Cold to Hot.
At speed droop variations up to 4.5%.

Frequency Regulation

Isochronous under varying loads from no load to 100% full load when electronic governor is fitted.

Random Frequency Variation

Will not exceed $\pm 0.25\%$ of its mean value for constant loads – no load to full load.

Waveform

Total harmonic distortion open circuit voltage waveform in the order of 1.8%. Three-phase balanced load in the order of 5.0%.

Telephone Influence Factor (TIF)

TIF better than 50.
THF to BS 4999 Part 40 better than 2%.

Alternator Temperature Rise

Class H insulation.

Radio Interference

In compliance with BS 800 and VDE levels G and N.

Features

Cummins® Heavy-Duty Engine - Rugged 4-cycle industrial diesel delivers reliable power, low emissions and fast response to load changes.

Optional Permanent Magnet Generator (PMG) - Offers enhanced motor starting and fault clearing short circuit capability.

Alternator - Low reactance 2/3 pitch windings; low waveform distortion with non-linear loads, fault clearing short-circuits capability, and class H insulation.

Cooling system - Standard integral set-mounted radiator system, designed and tested for rated ambient temperatures, simplifies facility design requirements for rejected heat.

Control system - The PowerCommand® electronic control is standard equipment and provides total genset system integration, including auto remote start/stop, alarm and status message display.

Enclosures - Optional weather-protective and sound-attenuated enclosures are available.

Warranty - Backed by a comprehensive warranty and worldwide distributor network.

Model	Standby Rating		Prime Rating	
	50Hz kVA (kW)	60Hz kW (kVA)	50Hz kVA (kW)	60Hz kW (kVA)
C70 D5	70 (56)	N/A	62.5 (50)	N/A
C80 D5	80 (64)	N/A	72.5 (58)	N/A
C90 D5	90 (72)	N/A	80 (64)	N/A
C100 D5	100 (80)	N/A	90 (72)	N/A

Generator Set Specifications

Governor Regulation Class	ISO8528
Voltage Regulation, No Load to Full Load	± 1%
Random Voltage Variation	± 1%
Frequency Regulation	Droop
Random Frequency Variation	± 0.25%
Radio Frequency Emissions Compliance	In compliance with BS 800 and VDE levels G and N.

Engine Specifications

Design	4 cycle, in-line, Turbo Charged
Bore	102 mm (4.02 in.)
Stroke	120 mm (4.72 in.)
Displacement	3.9 liter (239.3 in. ³)
Cylinder Block	Cast iron, 4 cylinder
Battery Capacity	100 A/hr
Battery Charging Alternator	65 amps
Starting Voltage	12 volt, 65Amp negative ground
Fuel System	Direct injection
Fuel Filter	Spin on fuel filters with water separator
Air Cleaner Type	Dry replaceable element with restriction indicator
Lube Oil Filter Type(s)	Spin on full flow filter
Standard Cooling System	122°F (50°C) ambient radiator

Alternator Specifications

Design	Brushless single bearing, revolving field
Stator	2/3 pitch
Rotor	Single bearing, flexible disc
Insulation System	Class H
Standard Temperature Rise	163°C - 125°C Standby/Prime
Exciter Type	Self Excited
Phase Rotation	A (U), B (V), C (W)
Alternator Cooling	Direct drive centrifugal blower fan
AC Waveform Total Harmonic Distortion	No load < 1.5%. Non distorting balanced linear load < 5%
Telephone Influence Factor (TIF)	<50 per NEMA MG1-22.43
Telephone Harmonic Factor (THF)	<2%

Available Voltages

50Hz Line – Neutral / Line - Line	60Hz Line – Neutral / Line - Line
240/416	277/480
230/400	220/380
220/380	139/240

Generator Set Options

Engine

Heavy Duty air filter
Water jacket heater 220/240 v

Cooling

Antifreeze 50/50 (Ethylene glycol)

Enclosure

Sound attenuated enclosure

Alternator

Alternator heater
Exciter voltage regulator (PMG)

Control Panel

4 pole Main Circuit Breaker

Silencer

Critical silencer
Residential silencer

Our energy working for you.™

www.cumminspower.com

© 2007 Cummins Power Generation Inc. All rights reserved. Cummins Power Generation and Cummins are registered trademarks of Cummins Inc. PowerCommand is a registered trademark of Cummins Power Generation Inc. "Our energy working for you." is a trademark of Cummins Power Generation.



Control System - PCC1301



The PowerCommand™ 1301 Control is a microprocessor-based generator set monitoring, and control system. The control provides a simple operator interface to the generator set, digital voltage regulation, digital engine speed governing, start / stop control, and protective functions.

The PowerCommand™ 1301 generator set control is suitable for use on a wide range of generator sets in non-parallel applications.

The PowerCommand™ Control can be configured for any frequency, voltage and power connection configuration from 120 to 600VAC for 50Hz or 60Hz operation.

Power for the control is derived from the generator set starting batteries. The control functions over a voltage range from 8VDC to 35VDC.

Major Features

- 12 or 24 VDC Battery Operation.
- Digital Engine Speed Governing (optional) to provide isochronous frequency regulation.
- Digital Voltage Regulation Full wave rectified single phase (line to line) sensing.
- Generator Set Monitoring. Monitors status of all critical engine and alternator conditions functions.
- Engine Starting includes relay drivers for start, fuel shut off (FSO), and glow plug.
- Configurable Inputs and Outputs. Two discrete inputs and two dry contact relay outputs.
- Generator set Monitoring: Displays status of all critical engine and alternator generator set functions.
- Smart Starting Control System: Integrated fuel ramping to limit black smoke and frequency overshoot.
- Advanced Serviceability using InPower™, a PC-based software service tool.

Control System

Includes all functions to locally or remotely start and stop, and protect the generator set.

Control Switch - RUN/OFF/AUTO

OFF Mode - the generator set is shut down and cannot be started; as well as resets faults.

RUN mode the generator set will execute its start sequence

AUTO mode, the generator set can be started with a start signal from a remote device

Status Indications - The control has a lamp driver for external fault/status indication. Functions include:

The lamp flashes during preheat (when used) and while the generator set is starting.

READY TO LOAD - flashing until the set is at rated voltage and frequency, then on continuously.

Fault conditions are displayed by flashing a two-digit fault code number.

LED Indicating Lamps - (optional display) includes LED indicating lamps for the following functions:

Not in auto

Remote start

Warning

Shutdown

Auto

Run

Remote Emergency Stop Switch Input. Immediate shut down of the generator set on operation.

Base Engine Protection:

Overspeed shutdown

Low oil pressure shutdown

High engine temperature shutdown

Underspeed/sensor fail shutdown

Fail to start

Battery charging alternator fail warning

Options

Digital Engine Speed Governing to provide isochronous frequency regulation.

Operator Display Panel an easy to use operator display of critical parameters and operating history.

Our energy working for you.™

www.cumminspower.com

© 2007 Cummins Power Generation Inc. All rights reserved. Cummins Power Generation and Cummins are registered trademarks of Cummins Inc. PowerCommand is a registered trademark of Cummins Power Generation Inc. "Our energy working for you." is a trademark of Cummins Power Generation.



Ratings Definitions

Standby:	Limited Time Running:	Prime (Unlimited Running Time):	Base Load (Continuous):
Applicable for supplying power to varying electrical load for the duration of power interruption of a reliable utility source. Emergency Standby Power (ESP) is in accordance with ISO 8528. Fuel Stop power in accordance with ISO 3046, AS 2789, DIN 6271 and BS 5514.	Applicable for supplying power to a constant electrical load for limited hours. Limited Time Running Power is in accordance with ISO 8528.	Applicable for supplying power to varying electrical load for unlimited hours. Prime Power is in accordance with ISO 8528. Ten percent overload capability is available in accordance with ISO 3046, AS 2789, DIN 6271 and BS 5514.	Applicable for supplying power continuously to a constant electrical load for unlimited hours. Continuous power in accordance with ISO 8528, ISO 3046, AS 2789, DIN 6271 and BS 5514.

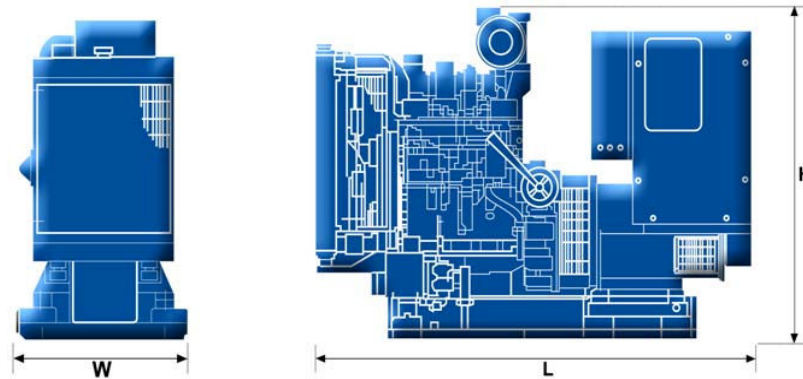

This outline drawing is to provide representative configuration details for Model series only.
See respective model data sheet for specific model outline drawing number.

Do not use for installation design.

Model	Length (mm)	Width (mm)	Height (mm)	Set weight dry kg	Set weight wet kg
C70 D5	1920	1050	1438	1060	1270
C80 D5	1920	1050	1438	1120	1335
C90 D5	1920	1050	1438	1165	1380
C100 D5	1920	1050	1438	1195	1405

Cummins Power Generation

P.M.G.,JSC

No1, Zone B, Alley 178 Giai Phong Str, Thanh Xuan

Dist, Hanoi City, Vietnam

Tel : (04) 36290294/22.431.521

Fax:(04) 36290295

www.mayphatdien-vn.com

Our energy working for you.™

www.cumminspower.com

© 2007 Cummins Power Generation Inc. All rights reserved. Cummins Power Generation and Cummins are registered trademarks of Cummins Inc. PowerCommand is a registered trademark of Cummins Power Generation Inc. "Our energy working for you." is a trademark of Cummins Power Generation.